

Making Temperature Measurements using Measurement Computing DAQ Products

THERMOCOUPLE BASICS

The Gradient Nature of Thermocouples

Thermocouples (TCs) are probably the most widely used and least understood of all temperature measuring devices. When connected in pairs, TCs are simple and efficient sensors that output an extremely small dc voltage proportional to the temperature difference between the two junctions in a closed thermoelectric circuit. (See Figure 6.01.) One junction is normally held at a constant reference temperature while the opposite junction is immersed in the environment to be measured. The principle of operation depends on the unique value of thermal emf measured between the open ends of the leads and the junction of two dissimilar metals held at a specific temperature. The principle is called the Seebeck Effect, named after the discoverer. The amount of voltage present at the open ends of the sensor and the range of temperatures the device can measure depend on the Seebeck coefficient, which in turn depends upon the chemical composition of the materials comprising the thermocouple wire.

The Seebeck voltage is calculated from:

Equation 6.01. Seebeck Voltage

$$\Delta e_{AB} = \alpha \Delta T$$

Where:

e_{AB} = Seebeck voltage

T = temperature at the thermocouple junction

α = Seebeck coefficient

Δ = a small change in voltage corresponding to a small change in temperature

Thermocouple junctions alone do not generate voltages. The voltage or potential difference that develops at the output (open) end is a function of both the temperature of the junction T_1 and the temperature of the open end T_1' . T_1' must be held at a constant temperature, such as 0°C , to ensure that the open end voltage changes in proportion to the temperature changes in T_1 . In principle,

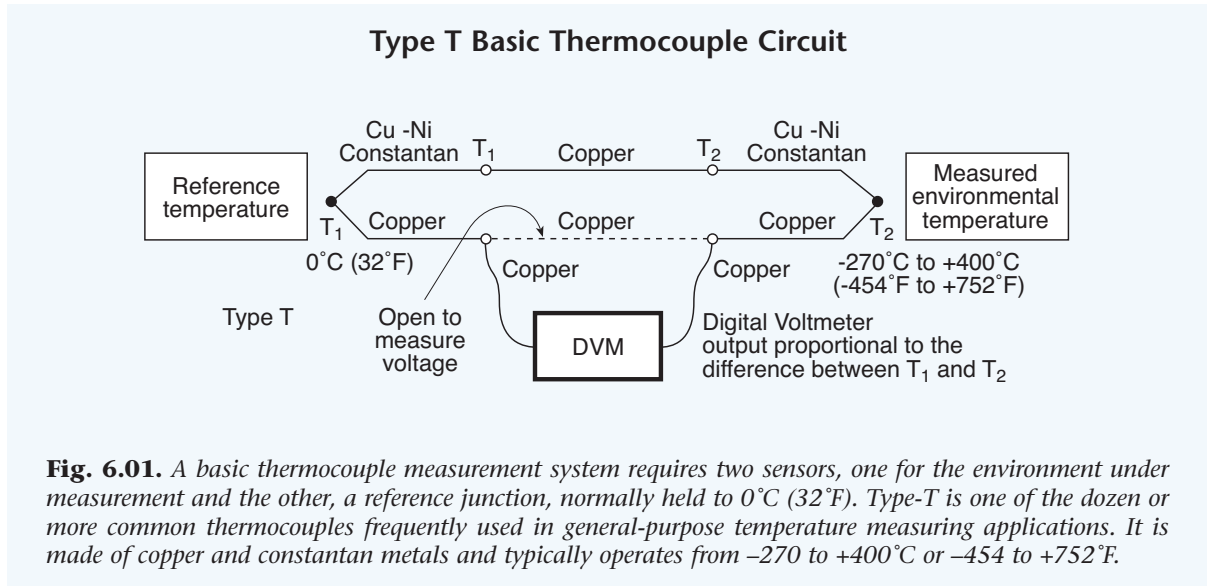

a TC can be made from any two dissimilar metals such as nickel and iron. In practice, however, only a few TC types have become standard because their temperature coefficients are highly repeatable, they are rugged, and they output relatively large voltages. The most common thermocouple types are called J, K, T, and E, followed by N28, N14, S, R, and B. (See the table in Figure 6.02.) In theory, the junction temperature can be inferred from the Seebeck voltage by consulting standard tables. In practice, however, this voltage cannot be used directly because the thermocouple wire connection to the copper terminal at the measurement device itself constitutes a thermocouple junction (unless the TC lead is also copper) and outputs another emf that must be compensated.

Cold-Junction Compensation

A cold-reference-junction thermocouple immersed in an actual ice-water bath and connected in series with the measuring thermocouple is the classical method used to compensate the emf at the instrument terminals. (See Figure 6.03.) In this example, both copper leads connect to the instrument's input terminals. An alternative method uses a single thermocouple with the copper/constantan connection immersed in the reference ice water bath, also represented in Figure 6.03. The constantan/copper thermocouple junction J_2 in the ice bath contributes a small emf that subtracts from the emf from thermocouple J_1 , so the voltage measured at the instrument or data acquisition system input terminals corresponds accurately to the NIST tables. Likewise, the copper wires connected to the copper terminals on the instrument's isothermal block do not need compensation because they are all copper at the same temperature. The voltage reading comes entirely from the NIST-adjusted constantan/copper thermocouple wire.

The above example is a special case, however, because one lead of the type-T thermocouple is copper. A constantan/iron thermocouple, on the other hand, needs further consideration. (See Figure 6.04.) Here, J_2 in the ice bath is held constant, and J_1

Alternate Thermocouple Ice Bath

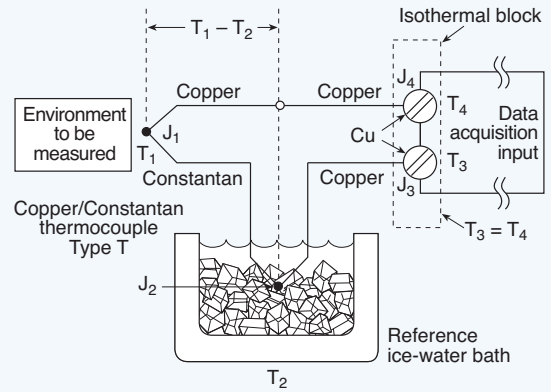

Fig. 6.03. Whether J_2 is a purchased thermocouple or not, the junction formed by the constantan and copper lead wires at J_2 must be placed in the ice bath for temperature compensation.

measures the environment. Although J_3 and J_4 are effectively thermocouple junctions, they are at the same temperature on the isothermal block, so they output equal and opposite voltages and thus cancel. The net voltage is then the thermocouple J_1 output representing T_1 , calibrated to the NIST standard table. If the I/O block were not isothermal, copper wire leads would be added between the input terminal and the copper/iron leads, and the copper/iron junctions (J_3 and J_4) would be held in an ice bath as well, as illustrated in Figure 6.05.

Software Compensation

Ice baths and multiple reference junctions in large test fixtures are nuisances to set up and maintain, and fortunately they all can be

Common Thermocouple Types								
Type	Metal		Standard color code		Ω /double foot 20 AWG	Seebeck coefficient $S(\mu V/^{\circ}C) @ T(^{\circ}C)$	$^{\circ}C$ standard wire error	NBS specified materials range* ($^{\circ}C$)
	+	-	+	-				
B	Platinum-6% Rhodium	Platinum-30% Rhodium	-	-	0.2	6 600	4.4 to 8.6	0 to 1820**
E	Nickel-10% Chromium	Constantan	Violet	Red	0.71	58.5 0	1.7 to 4.4	-270 to 1000
J	Iron	Constantan	White	Red	0.36	50.2 0	1.1 to 2.9	-210 to 760
K	Nickel-10% Chromium	Nickel	Yellow	Red	0.59	39.4 0	1.1 to 2.9	-270 to 1372
N (AWG 14)	Nicrosil	Nisil	-	-	-	39 600	-	0 to 1300
N (AWG 28)	Nicrosil	Nisil	-	-	-	26.2 0	-	-270 to 400
R	Platinum-13% Rhodium	Platinum	-	-	0.19	11.5 600	1.4 to 3.8	-50 to 1768
S	Platinum-10% Rhodium	Platinum	-	-	0.19	10.3 600	1.4 to 3.8	-50 to 1768
T	Copper	Constantan	Blue	Red	0.30	38 0	0.8 to 2.9	-270 to 400
W-Re	Tungsten-5% Rhenium	Tungsten-26% Rhenium	-	-	-	19.5 600	-	0 to 2320

* Material range is for 8 AWG wire; decreases with decreasing wire size
 ** Type B double-valued below $42^{\circ}C$ – curve fit specified only above $130^{\circ}C$

Fig. 6.02. NIST's (National Institute of Standards and Technology) thermocouple emf tables publish the emf output of a thermocouple based on a corresponding reference thermocouple junction held at $0^{\circ}C$.

Type J Thermocouple

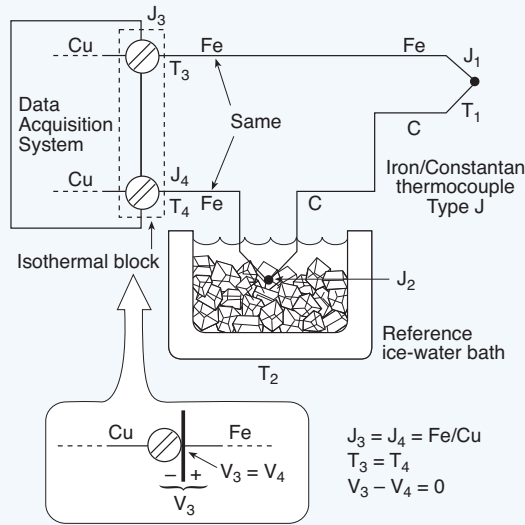

Fig. 6.04. One lead of a type-T thermocouple is copper, so it does not require temperature compensation when connecting to copper terminals. A Type J constantan/iron thermocouple, on the other hand, needs a closer look. J_2 remains constant in the ice bath, and J_1 measures the environment. Although J_3 and J_4 are effectively thermocouple junctions, they are at the same temperature on the isothermal block, so they generate equal and opposite voltages and cancel. Without an isothermal block, copper wire leads would be added between the input terminal and the copper/iron leads, and the copper/iron junctions (J_3 and J_4) would be held in an ice bath as well.

eliminated. The ice bath can be ignored when the temperature of the lead wires and the reference junction points (isothermal terminal block at the instrument) are the same. The emf correction needed at the terminals can be referenced and compensated to the NIST standards through computer software.

Chromel/Alumel Thermocouple

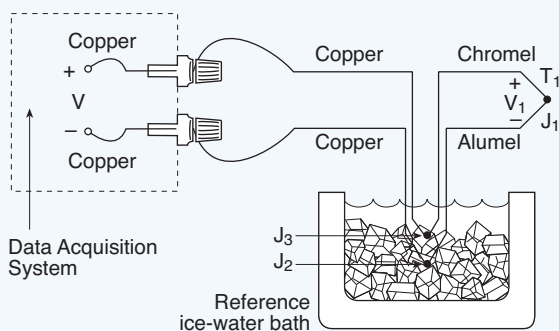

Fig. 6.05. The chromel and alumel wire connections at the copper leads constitute additional thermocouple junctions that must be held at the same, constant temperature. They generate equal and opposite potentials which prevent them from contributing to the voltage output from the chromel/alumel thermocouple.

Eliminating the Ice Bath

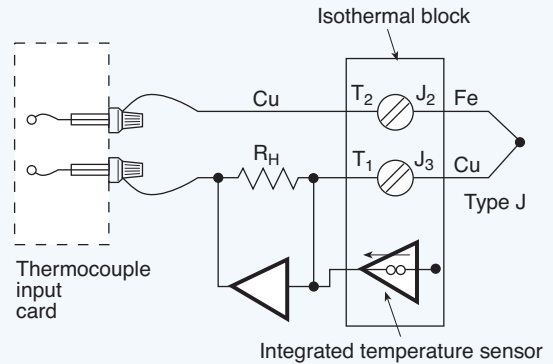

Fig. 6.06. A thermistor sensor placed near the lead wire connections is an alternative method of replacing the ice bath. The measured temperature is the difference between the thermocouple temperature and the reference thermistor temperature.

When the ice baths are eliminated, cold junction compensation (CJC) is still necessary, however, in order to obtain accurate thermocouple measurements. The software has to read the isothermal block temperature. One technique widely used is a thermistor, mounted close to the isothermal terminal block that connects to the external thermocouple leads. No temperature gradients are allowed in the region containing the thermistor and terminals. (See Figure 6.06.) The type of thermocouple employed is preprogrammed for its respective channel, and the dynamic input data for the software includes the isothermal block temperature and the measured environmental temperature. The software uses the isothermal block temperature and type of thermocouple to look up the value of the measured temperature corresponding to its voltage in a table, or it calculates the temperature more quickly with a polynomial equation. The method allows numerous channels of thermocouples of various types to be connected simultaneously while the computer handles all the conversions automatically.

Hardware Compensation

Although a polynomial approach is faster than a look-up table, a hardware method is even faster, because the correct voltage is immediately available to be scanned. One method is to insert a battery in the circuit to null the offset voltage from the reference junction so the net effect equals a 0°C junction. A more practical approach based on this principle is an “electronic ice point reference,” which generates a compensating voltage as a function of the temperature sensing circuit powered by a battery or similar voltage source. (See Figure 6.07A.) The voltage then corresponds to an equivalent reference junction at 0°C .

Type Mixing

Thermocouple test systems often measure tens to hundreds of points simultaneously. In order to conveniently handle such large numbers of channels without the complication of separate, unique compensation TCs for each, thermocouple-scanning modules come with multiple input channels and can accept any of the various types of thermocouples on any channel, simultaneously. They contain special copper-based input terminal blocks with numerous

Hardware Ice-Bath Replacement

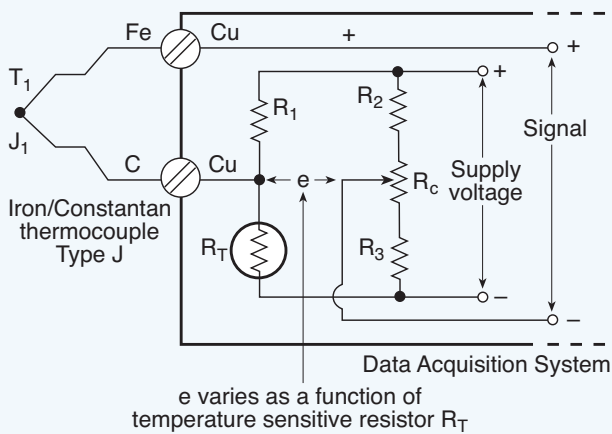

Fig. 6.07A. A number of electronic circuits or modules can replace the ice-bath. The temperature-sensitive resistor changes the calibrated value of voltage e in proportion to the amount of temperature compensation required.

cold junction compensation sensors to ensure accurate readings, regardless of the sensor type used. Moreover, the module contains a built-in automatic zeroing channel as well as the cold-junction compensation channel. Although measurement speed is relatively slower than most other types of scanning modules, the readings are accurate, low noise, stable, and captured in only ms. For example, one TC channel can be measured in 3 ms, 14 TC channels in 16 ms, and up to 56 channels in 61 ms. Typical measurement accuracies are better than 0.7°C , with channel-to-channel variation typically less than 0.5°C . (See Figure 6.07B.)

Linearization

After setting up the equivalent ice point reference emf in either hardware or software, the measured thermocouple output must be converted to a temperature reading. Thermocouple output is proportional to the temperature of the TC junction, but is not perfectly linear over a very wide range.

The standard method for obtaining high conversion accuracy for any temperature uses the value of the measured thermocouple voltage plugged into a characteristic equation for that particular type thermocouple. The equation is a polynomial with an order of six to ten. The computer automatically handles the calculation, but high-order polynomials take significant time to process. In order to accelerate the calculation, the thermocouple characteristic curve is divided into several segments. Each segment is then approximated by a lower order polynomial.

Analog circuits are employed occasionally to linearize the curves, but when the polynomial method is not used, the thermocouple output frequently connects to the input of an ADC where the correct voltage to temperature match is obtained from a table stored in the computer's memory. For example, one data acquisition system TC card includes a software driver that contains a temperature conversion library. It changes raw binary TC channels and CJC information into temperature readings. Some software packages for data acquisition systems supply CJC information and automatically linearize the thermocouples connected to the system.

THERMOCOUPLE MEASUREMENT PITFALLS

Noisy Environments

Because thermocouples generate a relatively small voltage, noise is always an issue. The most common source of noise is the utility power lines (50 or 60 Hz). Because thermocouple bandwidth is

Hardware Ice-Bath Replacement

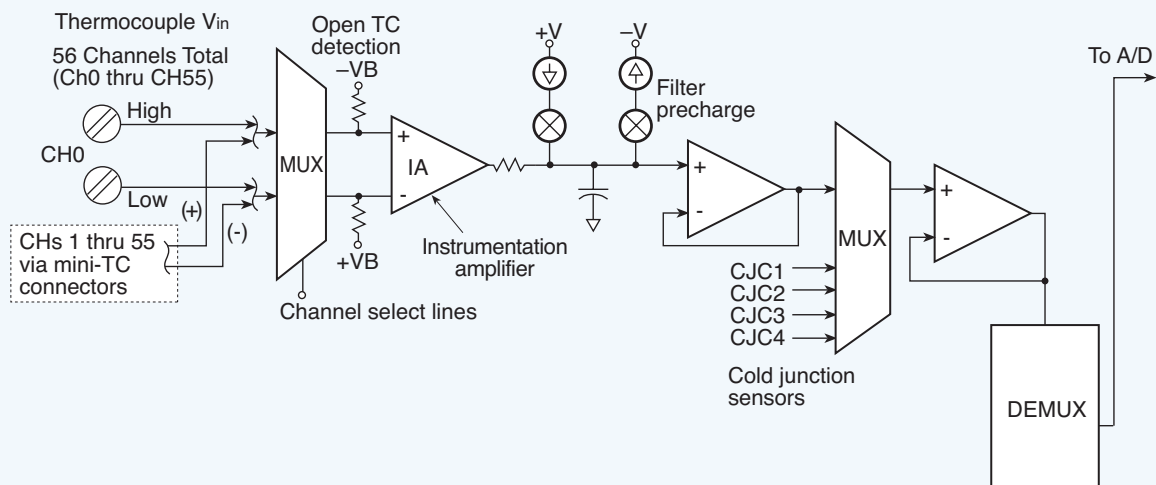

Fig. 6.07B. A typical input scanning module can accommodate up to 56 thermocouples of any type, and up to 896 channels can be connected to one analog-to-digital mainframe.

Passive Filters

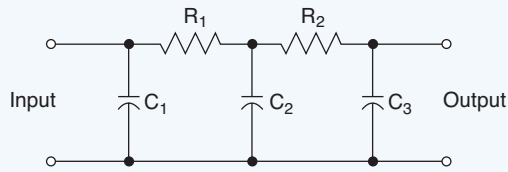

Fig. 6.08A. Passive filters come in a variety of configurations to suit the application. They are built in single or multiple sections to provide increasingly steeper slopes for faster roll-off.

Active Filters

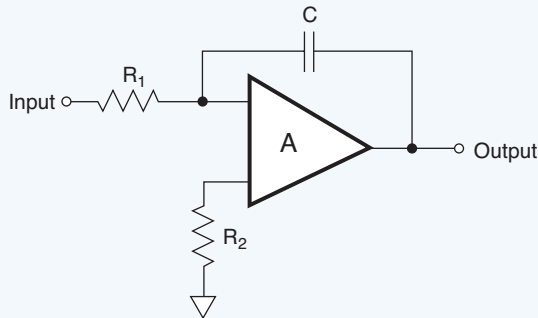

Fig. 6.08B. An active filter easily eliminates the most common sources of electrical noise that competes with the thermocouple signal such as the interference from 50/60 Hz supply lines.

lower than 50 Hz, a simple filter in each channel can reduce the interfering ac line noise. Common filters include resistors and capacitors and active filters built around op amps. Although a passive RC filter is inexpensive and works well for analog circuits, it's not recommended for a multiplexed front end because the multiplexer's load can change the filter's characteristics. On the other hand, an active filter composed of an op amp and a few passive components works well, but it's more expensive and complex. Moreover, each channel must be calibrated to compensate for gain and offset errors. (See Figure 6.08.)

Additional Concerns

Thermocouple Assembly

Thermocouples are twisted pairs of dissimilar wires that are soldered or welded together at the junction. When not assembled properly, they can produce a variety of errors. For example, wires should not be twisted together to form a junction; they should be soldered or welded. However, solder is sufficient only at relatively low temperatures, usually less than 200°C. And although soldering also introduces a third metal, such as a lead/tin alloy, it will not likely introduce errors if both sides of the junction are at the same temperature. Welding the junction is preferred, but it must be done without changing the wires' characteristics. Commercially manufactured thermocouple junctions are typically joined with capacitive discharge welders that ensure uniformity and prevent contamination.

Virtual Junction

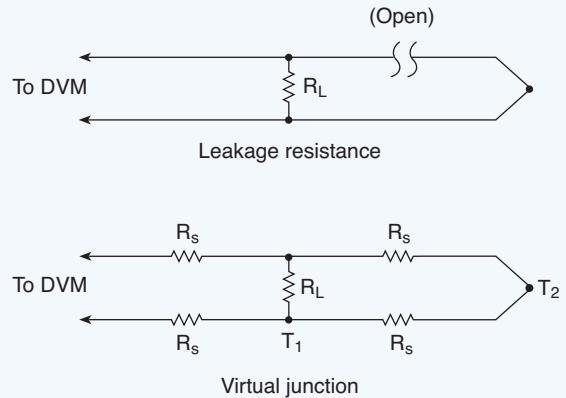

Fig. 6.09. A short circuit or an insulation failure between the leads of a thermocouple can form an unwanted, inadvertent thermocouple junction called a virtual junction.

Thermocouples can become un-calibrated and indicate the wrong temperature when the physical makeup of the wire is altered. Then it cannot meet the NIST standards. The change can come from a variety of sources, including exposure to temperature extremes, cold working the metal, stress placed on the cable when installed, vibration, or temperature gradients.

The output of the thermocouple also can change when its insulation resistance decreases as the temperature increases. The change is exponential and can produce a leakage resistance so low that it bypasses an open-thermocouple wire detector circuit. In high-temperature applications using thin thermocouple wire, the insulation can degrade to the point of forming a virtual junction as illustrated in Figure 6.09. The data acquisition system will then measure the output voltage of the virtual junction at T_1 instead of the true junction at T_2 .

In addition, high temperatures can release impurities and chemicals within the thermocouple wire insulation that diffuse into the thermocouple metal and change its characteristics. Then, the temperature vs. voltage relationship deviates from the published values. Choose protective insulation intended for high-temperature operation to minimize these problems.

Thermocouple Isolation

Thermocouple isolation reduces noise and errors typically introduced by ground loops. This is especially troublesome where numerous thermocouples with long leads fasten directly between an engine block (or another large metal object) and the thermocouple-measurement instrument. They may reference different grounds, and without isolation, the ground loop can introduce relatively large errors in the readings.

Auto-Zero Correction

Subtracting the output of a shorted channel from the measurement channel's readings can minimize the effects of time and temperature drift on the system's analog circuitry. Although extremely small, this drift can become a significant part of the low-level voltage supplied by a thermocouple.

Auto-Zero Correction

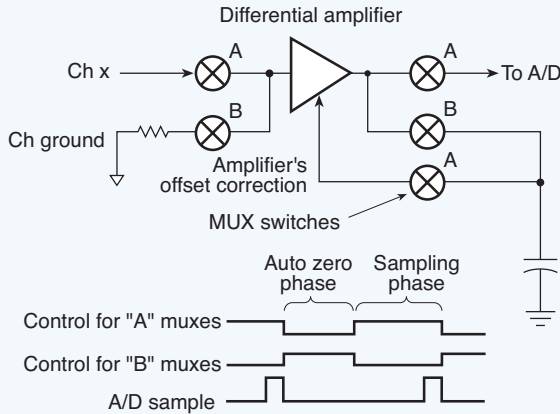

Fig. 6.10. Auto-Zero Correction compensates for analog circuitry drift over time and temperature. Although small, the offset could approach the magnitude of the thermocouple signal.

One effective method of subtracting the offset due to drift is done in two steps. First, the internal channel sequencer switches to a reference node and stores the offset error voltage on a capacitor. Next, as the thermocouple channel switches onto the analog path, the stored error voltage is applied to the offset correction input of a differential amplifier and automatically nulls out the offset. (See Figure 6.10.)

Open Thermocouple Detection

Detecting open thermocouples easily and quickly is especially critical in systems with numerous channels. Thermocouples tend to break or increase resistance when exposed to vibration, poor handling, and long service time. A simple open-thermocouple detection circuit comprises a small capacitor placed across the thermocouple leads and driven with a low-level current. The low impedance of the intact thermocouple presents a virtual short circuit to the capacitor so it cannot charge. When a thermocouple opens or significantly changes resistance, the capacitor charges and drives the input to one of the voltage rails, which indicates a defective thermocouple. (See Figure 6.11.)

Galvanic Action

Some thermocouple insulating materials contain dyes that form an electrolyte in the presence of water. The electrolyte generates a galvanic voltage between the leads, which in turn, produces output signals hundreds of times greater than the net open-circuit voltage. Thus, good installation practice calls for shielding the thermocouple wires from high humidity and all liquids to avoid such problems.

Thermal Shunting

An ideal thermocouple does not affect the temperature of the device being measured, but a real thermocouple has mass that when added to the device under test can alter the temperature measurement. Thermocouple mass can be minimized with small diameter wires, but smaller wire is more susceptible to contamination, annealing, strain, and shunt impedance. One solution to help

Open Thermocouple Detector

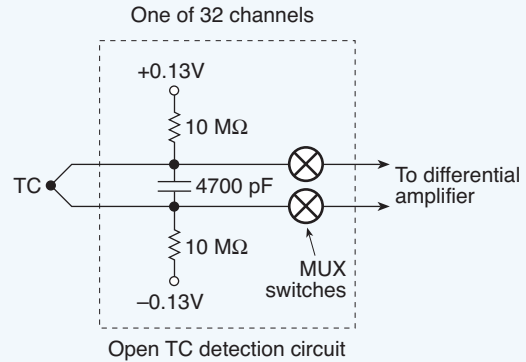

Fig. 6.11. The thermocouple provides a short-circuit path for dc around the capacitor, preventing it from charging through the resistors. When the thermocouple opens, due to rough handling or vibration, the capacitor charges and drives the input amplifier to the power supply rails, signaling a failure.

ease this problem is to use the small thermocouple wire at the junction but add special, heavier thermocouple extension wire to cover long distances. The material used in these extension wires has net open-circuit voltage coefficients similar to specific thermocouple types. Its series resistance is relatively low over long distances, and it can be pulled through conduit easier than premium grade thermocouple wire. In addition to its practical size advantage, extension wire is less expensive than standard thermocouple wire, especially platinum.

Despite these advantages, extension wire generally operates over a much narrower temperature range and is more likely to receive mechanical stress. For these reasons, the temperature gradient across the extension wire should be kept to a minimum to ensure accurate temperature measurements.

Improving Wire Calibration Accuracy

Thermocouple wire is manufactured to NIST specifications. Often, these specifications can be met more accurately when the wire is calibrated on site against a known temperature standard.

RTD MEASUREMENTS

Basics of Resistance Temperature Detectors

RTDs are composed of metals with a high positive temperature coefficient of resistance. Most RTDs are simply wire-wound or thin film resistors made of material with a known resistance vs. temperature relationship. Platinum is one of the most widely used materials for RTDs. They come in a wide range of accuracies, and the most accurate are also used as NIST temperature standards.

Platinum RTD resistances range from about 10 Ω for a birdcage configuration to 10 k Ω for a film type, but the most common is 100 Ω at 0°C. Commercial platinum wire has a standard temperature coefficient, α , of 0.00385 $\Omega/\Omega/^\circ\text{C}$, and chemically pure platinum has a coefficient of 0.00392 $\Omega/\Omega/^\circ\text{C}$.

Two-Wire RTD

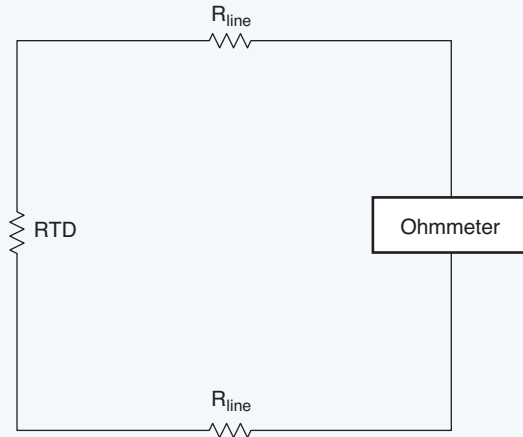

Fig. 6.12. The simplest arrangement for an RTD measurement is a simple series circuit containing only two wires connected to an ohmmeter.

Four-Wire RTD with Current Source

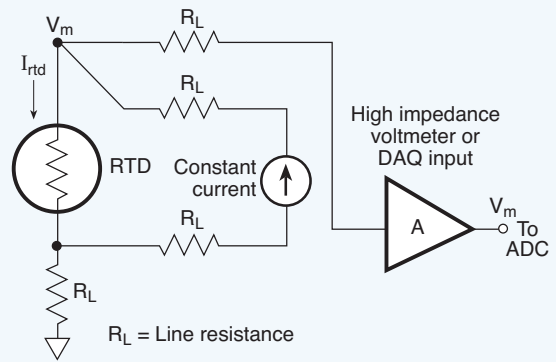

Fig. 6.13. The four-wire RTD method with a current supply eliminates the lead wire resistance as a source of error.

The following equation shows the relationship between the sensor's relative change in resistance with a change in temperature at a specific α and nominal sensor resistance.

Equation 6.02. RTD Temperature Coefficient

$$\Delta R = \alpha R_0 \Delta T$$

Where:

α = temperature coefficient, $\Omega/\Omega/^\circ\text{C}$

R_0 = nominal sensor resistance at 0°C , Ω

ΔT = change in temperature from 0°C , $^\circ\text{C}$

A nominal 100Ω platinum wire at 0°C will change resistance, either plus or minus, over a slope of $0.385 \Omega/^\circ\text{C}$. For example, a 10°C rise in temperature will change the output of the sensor from 100Ω to 103.85Ω , and a 10°C fall in temperature will change the RTD resistance to 96.15Ω .

Because RTD sensor resistances and temperature coefficients are relatively small, lead wires with a resistance as low as ten ohms and relatively high temperature coefficients can change the data acquisition system's calibration. The lead wire's resistance change over temperature can add to or subtract from the RTD sensor's output and produce appreciable errors in temperature measurement.

The resistance of the RTD (or any resistor) is determined by passing a measured current through it from a known voltage source. The resistance is then calculated using Ohms Law. To eliminate the measurement error contributed by lead wires, a second set of voltage sensing leads should be connected to the sensor's terminals and the opposite ends connected to corresponding sense terminals at the signal conditioner. This is called a four-wire RTD measurement. The sensor voltage is measured directly and eliminates the voltage drop in the current carrying leads.

Measurement Approaches

2-, 3-, and 4-wire Configurations

Five types of circuits are used for RTD measurements using two, three, and four lead wires: Two-wire with current source, four-wire with current source, three-wire with current source, four-wire with voltage source, and three-wire with voltage source.

Figure 6.12 shows a basic two-wire resistance measurement method. The RTD resistance is measured directly from the Ohmmeter. But this connection is rarely used since the lead wire resistance and temperature coefficient must be known. Often, both properties are not known, nor are they convenient to measure when setting up a test.

Figure 6.13 shows a basic four-wire measurement method using a current source. The RTD resistance is V/A . This connection is more accurate than the two-wire method, but it requires a high stability current source and four lead wires. Because the high-impedance voltmeter does not draw appreciable current, the voltage across the RTD equals V_m .

Equation 6.03. 4-Wire RTD With Current Source

$$R_{\text{rtd}} = \frac{V_m}{I_{\text{rtd}}}$$

Where:

R_{rtd} = RTD resistance, Ω

V_m = Voltmeter reading, V

I_{rtd} = RTD current, A

Figure 6.14 shows a three-wire measurement technique using a current source. The symbols V_a and V_b represent two voltages measured by the high-impedance voltmeter in sequence through switches (or a MUX), S_1 and S_2 . The RTD resistance is derived from Kirchhoff's voltage law and by solving two simultaneous

Three-Wire RTD With Current Source

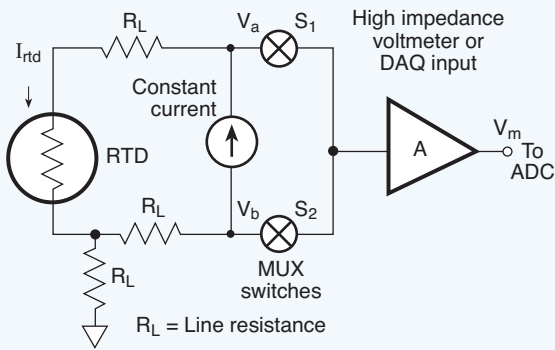

Fig. 6.14. The three-wire RTD method with a current supply is similar to the four-wire method. It simply eliminates one additional wire. Measure V_a first, then measure V_b .

Four-Wire RTD With Voltage Source

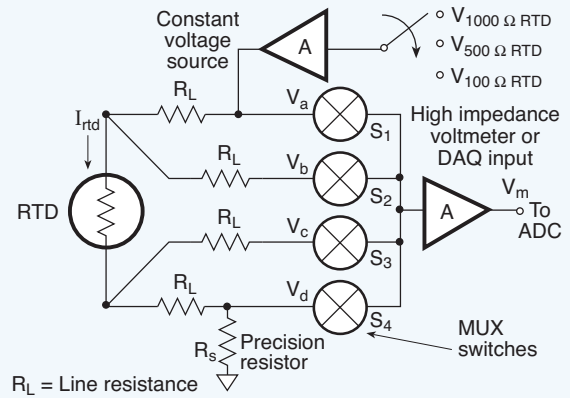

Fig. 6.15. The four-wire RTD circuit with a voltage source is more complex than the four-wire with current source, but the voltage is allowed to vary somewhat provided the sense resistor is stable.

equations. (Illustrating the solution is beyond the scope of this book.) The benefit of this connection over that shown in Figure 6.13 is one less lead wire. However, this connection assumes that the two current-carrying wires have the same resistance.

Equation 6.04. 3-Wire RTD With Current Source

$$R_{rtd} = \frac{(V_a - V_b)}{I_{rtd}}$$

Figure 6.15 shows a four-wire measurement system using a voltage source. The RTD resistance is derived from Kirchhoff's voltage law and four simultaneous equations based on the four voltages, V_a through V_d . The voltage source in this circuit can vary somewhat as long as the sense resistor remains stable.

Equation 6.05. 4-Wire RTD With Voltage Source

$$R_{rtd} = \frac{R_s (V_b - V_c)}{V_d}$$

Figure 6.16 shows a three-wire measurement technique using a voltage source. The RTD resistance is derived from Kirchhoff's voltage law and three simultaneous equations. The voltage source can vary as long as the sense resistor remains stable, and the circuit is accurate as long as the resistances of the two current-carrying wires are the same.

Equation 6.06. 3-Wire RTD With Voltage Source

$$R_{rtd} = \frac{R_s (2V_b - V_a - V_d)}{V_d}$$

Three-Wire RTD With Voltage Source

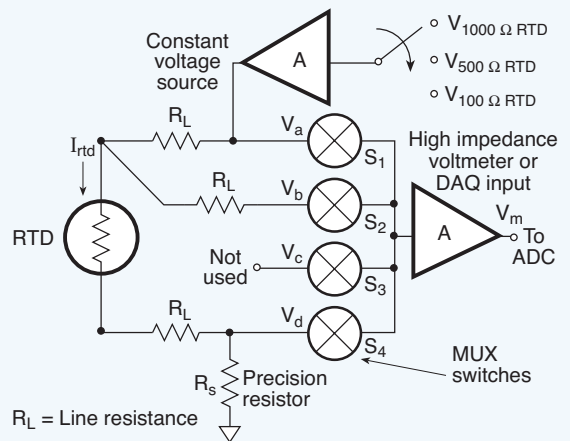

Fig. 6.16. This is a variation of the four-wire circuit with a voltage source and a stable sense resistor.

The RTD output is more linear than the thermocouple, but its range is smaller. The Callendar-Van Dusen equation is often used to calculate the RTD resistance:

Equation 6.07. RTD Curve Fitting

$$R_T = R_0 + R_0 \alpha \left[T - \delta \left(\frac{T}{100} - 1 \right) \left(\frac{T}{100} \right) - \beta \left(\frac{T}{100} - 1 \right) \left(\frac{T}{100} \right)^3 \right]$$

Where:

R_T = resistance at T , Ω

R_0 = resistance at $T = 0^\circ\text{C}$, Ω

α = temperature coefficient at $T = 0^\circ\text{C}$

$\delta = 1.49$ (for platinum)

$\beta = 0$, when $T > 0$

$\beta = 0.11$ when $T < 0$

Type S Thermocouple vs. Platinum RTD

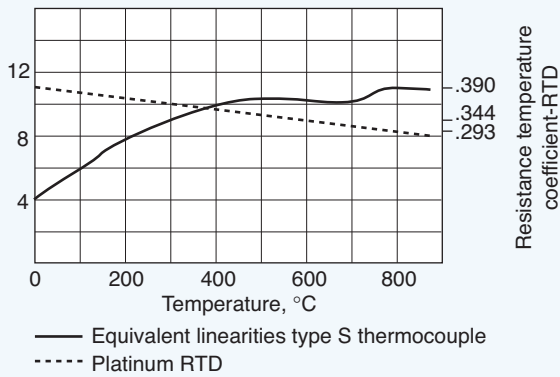

Fig. 6.17. Platinum is the material of choice for RTDs and thermocouples because it is stable and resists corrosion. Here, the RTD is shown to be more linear under temperatures of 800°C than the thermocouple.

Constant-Current Scanning Module

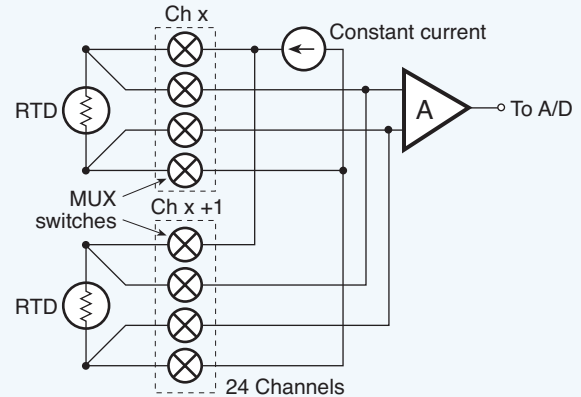

Fig. 6.18. The constant-current source is sequentially switched among the various RTD sensors to keep them cooler over the measurement interval and prevent resistive-heating errors.

An alternative method involves measuring RTD resistances at four temperatures and solving a 20th order polynomial equation with these values. It provides more precise data than does the α , δ , and β coefficients in the Callendar-Van Dusen equation. The plot of the polynomial equation in Figure 6.17 shows the RTD to be more linear than the thermocouple when used below 800°C, the maximum temperature for RTDs.

Self-Heating

Another source of error in RTD measurements is resistive heating. The current, I , passing through the RTD sensor, R , dissipates power, $P = I^2R$. For example, 1 mA through a 100 Ω RTD generates 100 μ W. This may seem insignificant, but it can raise the temperature of some RTDs a significant fraction of a degree. A typical RTD can change 1°C/mW by self-heating. When selecting smaller RTDs for faster response times, consider that they also can have larger self-heating errors.

A typical value for self-heating error is 1°C/mW in free air. An RTD immersed in a thermally conductive medium distributes this heat to the medium and the resulting error is smaller. The same RTD rises 0.1°C/mW in air flowing at one m/s. Using the minimum excitation current that provides the desired resolution, and using the largest physically practical RTD will help reduce self-heating errors.

Scanning Inputs

Because lower currents generate less heat, currents between 100 and 500 μ A are typically used. This lowers the power dissipation to 10 to 25 μ W, which most applications can tolerate. Further reducing the current lowers accuracy because they become more susceptible to noise and are more difficult to measure. But switching the current on only when the measurement is made can reduce the RTD's heat to below 10 μ W. In a multichannel system, for example, the excitation current can be multiplexed, much like the analog inputs. In a 16-channel system, the current will only excite each RTD 1/16th of the time, reducing the power delivered to each RTD from 100% to only 6%.

Two practical methods for scanning an RTD include constant current and ratiometric. An example of a constant current circuit is shown in Figure 6.18. It's an RTD scanning module, which switches a single 500 μ A constant current source among 16 channels. A series of front-end multiplexers direct the current to each channel sequentially while the measurement is being taken. Both three and four wire connections are supported to accommodate both types of RTDs. By applying current to one RTD at a time, errors due to resistive heating become negligible. Advantages of the constant current method include simple circuits and noise immunity. But the disadvantage is the high cost of buying or building an extremely stable constant current source.

Ratiometric Four-Wire RTD

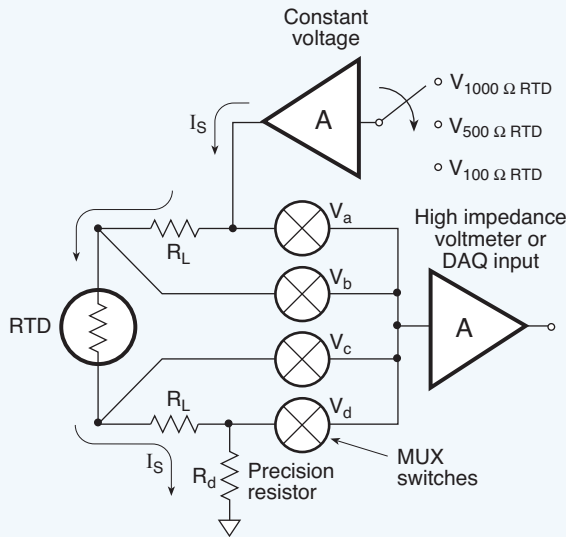

Fig. 6.19. Four voltage readings are taken for each RTD channel. The precision resistor measures I_s , the RTD current; V_b and V_c measure the RTD voltage; and the RTD resistance equals $(V_b - V_c)/I_s$.

Ratiometric Three-Wire RTD

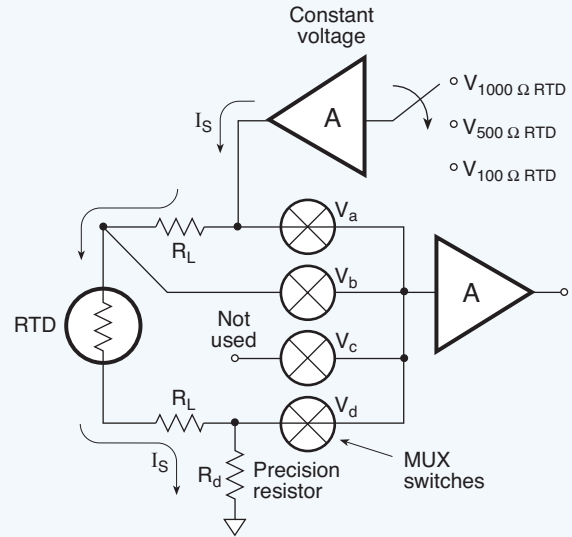

Fig. 6.20. The three-wire ratiometric circuit assumes that both sense-wire resistances in the four-wire circuit are the same. The equation for calculating RTD resistance simply accounts for it with a factor of two.

By contrast, the ratiometric method uses a constant voltage source to provide a current, I_s , through the RTD and a resistor, R_d . Four voltage readings are taken for each RTD channel, V_a , V_b , V_c , and V_d . (See Figure 6.19.)

The current, voltage, and resistance of the RTD is:

Equation 6.08. 4-Wire RTD Ratiometric Measurement

$$I_s = \frac{V_d}{R_d}$$

$$V_{rtd} = V_b - V_c$$

$$R_{rtd} = \frac{V_{rtd}}{I_s}$$

For a three-wire connection (Figure 6.20), the voltage, $V_a - V_c$, includes the voltage drop across only one lead. Because the two extension wires to the transducer are made of the same metal, assume that the drop in the first wire is equal to the drop in the second wire. Therefore, the voltage across the RTD and its resistance is:

Equation 6.09. 3-Wire RTD Ratiometric Measurement

$$V_{rtd} = V_a - 2(V_a - V_b) - V_d$$

$$R_{rtd} = R_d \left(\frac{V_{rtd}}{V_d} \right)$$

RTD Resistance Comparison: Small Resistance vs. Large Resistance		
	Small RTD	Large RTD
Response time	Fast	Slow
Thermal shunting	Low	Poor
Self-heating error	High	Low

Fig. 6.21. Although smaller RTDs respond faster to temperature changes, they are more susceptible to inaccuracy from self-heating.

Practical Precautions

RTDs require the same precautions that apply to thermocouples, including using shields and twisted-pair wire, proper sheathing, avoiding stress and steep gradients, and using large diameter extension wire. In addition, the RTD is more fragile than the thermocouple and needs to be protected during use. Also, thermal shunting is a bigger concern for RTDs than for thermocouples because the mass of the RTD is generally much larger. (See Figure 6.21.)

THERMISTOR MEASUREMENTS

Basics of Thermistors

Thermistors are similar to RTDs in that they also change resistance between their terminals with a change in temperature. However, they can be made with either a positive or negative temperature coefficient. In addition, they have a much higher ratio of resistance change per °C (several %) than RTDs, which makes them more sensitive.

Linearize Thermistor Output Voltage

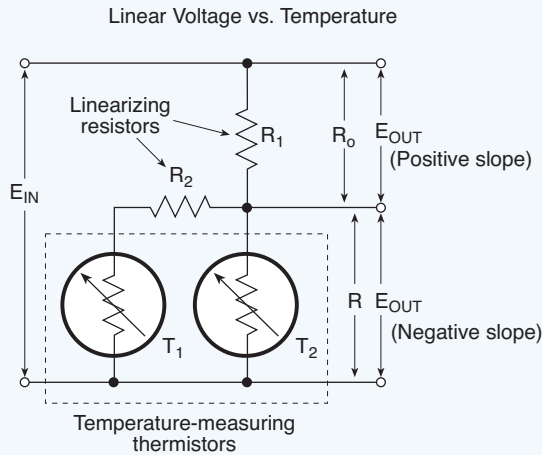

Fig. 6.22. The compensating resistors in series with the thermistors improve linearity near the center of the thermistor's S-shaped characteristic curve. This is where the sensitivity is the greatest, and its operating temperatures can be extended to cover a wider range.

Thermistors are generally composed of semiconductor materials or oxides of common elements such as cobalt, copper, iron, manganese, magnesium, nickel, and others. They typically come with 3 to 6 in. leads, encapsulated, and color-coded. They are available in a range of accuracies from $\pm 15^\circ\text{C}$ to $\pm 1^\circ\text{C}$, with a nominal resistance ranging from 2,000 to 10,000 Ω at 25°C . A value of 2252 Ω is common and can be used with most instruments. A plot of the temperature vs. resistance characteristic curves is usually provided with the device to determine the temperature from a known resistance. However, the devices are highly non-linear and the following equation may be used to calculate the temperature:

Equation 6.10. Thermistor Temperature

$$\frac{1}{T} = A + B(\log_e R) + C(\log_e R)^3$$

Where:

T = temperature, $^\circ\text{K}$

A, B, and C = fitting constants

R = resistance, Ω

The constants A, B, and C are calculated from three simultaneous equations with known data sets: Insert R_1 and T_1 ; R_2 and T_2 ; R_3 and T_3 , then solve for A, B, and C. Interpolation yields a solution accurate to $\pm 0.01^\circ\text{C}$ or better.

Linearize Thermistor Output Resistance

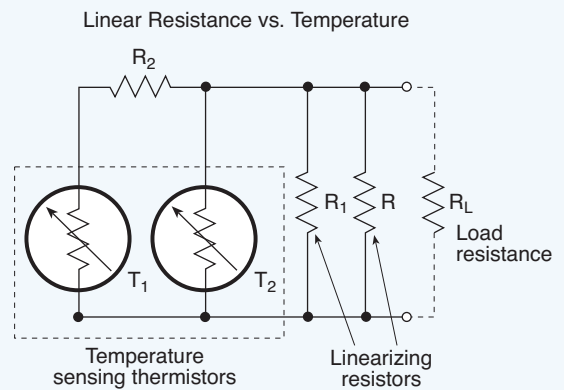

Fig. 6.23. Compensating resistors in the network linearize the resistance change vs. temperature in the same manner as they do for the voltage mode.

Linearization

Some thermistor manufacturers supply devices that provide a near-linear output. They use multiple thermistors (positive and negative coefficients) or a combination of thermistors and metal film resistors in a single package. When connected in certain networks, they produce a linearly varying voltage or resistance proportional to temperature. A widely used equation for the voltage divider shown in Figure 6.22 is:

Equation 6.11. Thermistor Voltage Divider

$$E_{out} = E_{in} \left(\frac{R}{R + R_0} \right)$$

Where:

E_{out} is the voltage drop across R

If R is a thermistor, and the output voltage is plotted against the temperature, the curve resembles an S-shape with a fairly straight center portion. However, adding other resistors or thermistors to R linearizes the center portion of the curve over a wider temperature range. The linear section follows the equation of a straight line, $Y = mX + b$:

For the voltage mode:

Equation 6.12. Thermistor Voltage Mode

$$E_{out} = \pm MT + b$$

Where:

T = temperature in $^\circ\text{C}$ or $^\circ\text{F}$

b = value of E_{out} when $T = 0$

M = slope, volts per degree T in $^\circ\text{C}$ or $^\circ\text{F}$, $\text{V}/^\circ\text{C}$ or $\text{V}/^\circ\text{F}$

For the resistance mode, see Figure 6.23.

Equation 6.13. Thermistor Resistance Mode

$$R_t = MT + b$$

Where:

T = temperature in °C or °F

b = value of the total network resistance R_t in Ω when
T = 0

M = slope, Ω per degree T in °C or °F,
 $\Omega/^\circ\text{C}$ or $\Omega/^\circ\text{F}$

Although a lot of research has gone into developing linear thermistors, most modern data acquisition system controllers and software handle the linearization, which makes hardware linearization methods virtually obsolete.

Stability

Thermistors are inherently and reasonably stable devices, not normally subject to large changes in nominal resistance with aging, nor with exposure to strong radiation fields. However, prolonged operation over 90°C can change the tolerance of thermistors, particularly those with values less than 2,000 Ω . They are smaller and more fragile than thermocouples and RTDs, so they cannot tolerate much mishandling.

Time Constant

The time required for a thermistor to reach 63% of its final resistance value after being thrust into a new temperature environment is called its time constant. The time constant for an unprotected thermistor placed in a liquid bath may range from 1 to 2.5 sec. The same device exposed to an air environment might require 10 sec, while an insulated unit could require up to 25 sec. Seven time constants is a universally accepted value to consider when the device has reached its plateau or about 99% of its final value. Therefore, a device in the liquid bath might take as long as 7 sec to stabilize, while the same device in air could take 125 seconds or more than two minutes.

Dissipation Factor

The power required to raise the temperature of a thermistor 1°C above the ambient is called the dissipation factor. It is typically in the mW range for most devices. The maximum operating temperature for a thermistor is about 150°C.

Tolerance Curves

Manufacturers have not standardized on thermistor characteristic curves to the extent they have for thermocouples and RTDs. Thermistors are well suited to measuring temperature set points, and each thermistor brand comes with its unique curve which is often used to design ON/OFF control circuits.

Measurement Approaches

Temperature Measurement

Wheatstone bridge: Thermistors provide accurate temperature measurements when used in one leg of a Wheatstone bridge, even at considerable distances between the thermistor and the bridge circuit. (See Figure 6.24A.) The lead length is not a critical factor because the thermistor resistance is many times that of the lead wires. Numerous thermistors can be widely distributed throughout the lab or facility and switched into the data acquisition system without significant voltage drops across the switch contacts. (See Figure 6.24B.)

Differential thermometers: Two thermistors can be used in a Wheatstone bridge to accurately measure the difference in temperature between them. Thermistors can be attached to any heat conducting medium in a system at various points to measure the temperature gradient along its length. Two or more thermistors may be placed in a room to measure temperatures at several different elevations using the same basic switching arrangement.

Thermistors in a Wheatstone Bridge

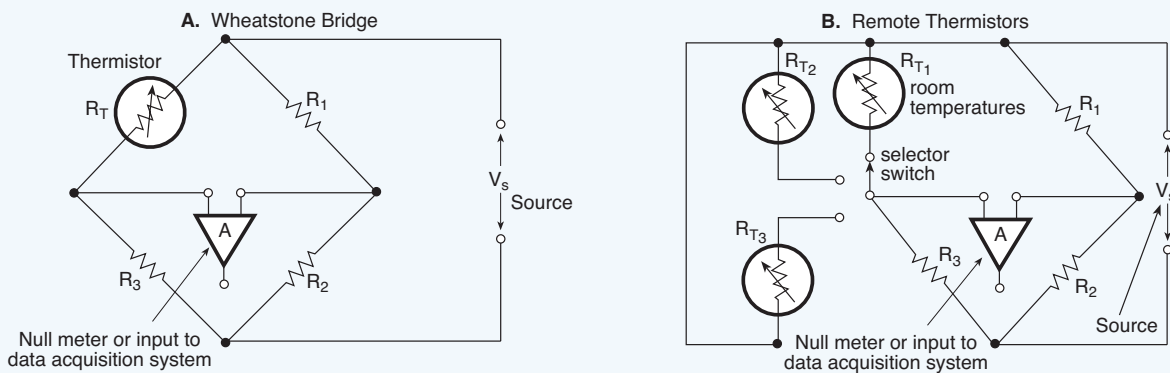

Fig. 6.24. An accurate temperature sensor can be fashioned from a thermistor in one leg of a bridge circuit. Lead length is not significant; so several sensors may be switched in and out of a single monitor without losing accuracy. Two thermistors make a differential thermometer that can be used for measuring temperature changes along a piping system or between various elevations in a building to balance the heating and air conditioning unit.

Temperature Measurement Solutions

HIGH-ACCURACY MULTIFUNCTION USB-2416 Series



- 24-bit resolution
- Measure thermocouples or voltage
- 32 single ended/16 differential inputs
- Up to 4 analog outputs, digital I/O, counters
- Expandable to 64 channels
- Included software and drivers

LOWEST COST USB-TEMP and TC Series



- Measure thermocouples, RTDs, thermistors, or voltage
- 8 channels
- 24-bit resolution
- Included software and drivers

SINGLE-CHANNEL DAQFlex USB-2001-TC



- DAQFlex text-based programming protocol for Windows® or Linux®
- Single-channel thermocouple measurements
- 20-bit resolution

WIRELESS MEASUREMENTS WLS-TEMP and TC Series



- Wireless range: up to 2,400 feet
- Measure thermocouples, RTDs, or thermistors
- 8 channels
- 24-bit resolution
- Included software and drivers

STAND-ALONE DATA LOGGERS USB-5200 Series



- Measure thermocouples, RTDs, or thermistors
- 8 channels, 24-bit resolution
- 8 digital I/O; configurable for alarming
- Included CompactFlash® memory, software, and drivers

LOW-COST DATA LOGGERS USB-500 Series



- Measure temperature, humidity, voltage, or current
- Up to 32k readings
- Battery powered
- Internal memory
- Included software