

SCM5B37

Thermocouple Input Modules



Description

Each SCM5B37 thermocouple input module provides a single channel of thermocouple input which is filtered, isolated, amplified, and converted to a high level analog voltage output (Figure 1). This voltage output is logic-switch controlled, allowing these modules to share a common analog bus without the requirement of external multiplexers.

The SCM5B modules are designed with a completely isolated computer side circuit which can be floated to $\pm 50V$ from Power Common, pin 16. This complete isolation means that no connection is required between I/O Common and Power Common for proper operation of the output switch. If desired, the output switch can be turned on continuously by simply connecting pin 22, the Read-Enable pin, to I/O Common, pin 19.

The SCM5B37 can interface to nine industry standard thermocouple types: J, K, T, E, R, S, C, N, and B. Its corresponding output signal operates over a 0V to +5V range. Each module is cold-junction compensated to correct for parasitic thermocouples formed by the thermocouple wire and screw terminals on the mounting backpanel. Upscale open thermocouple detect is provided by an internal pull-up resistor. Downscale indication can be implemented by installing an external $47M\Omega$ resistor, $\pm 20\%$ tolerance, between screw terminals 1 and 3 on the SCMPB01/02/03/04/05/06/07 backpanels.

Signal filtering is accomplished with a six-pole filter which provides 95dB of normal-mode-rejection at 60Hz and 90dB at 50Hz. Two poles of this filter are on the field side of the isolation barrier, and the other four are on the computer side.

After the initial field-side filtering, the input signal is chopped by a proprietary chopper circuit. Isolation is provided by transformer coupling, again using a proprietary technique to suppress transmission of common mode spikes or surges. The module is powered from +5VDC, $\pm 5\%$.

► Features

- Interfaces to Types J, K, T, E, R, S, C, N and B Thermocouples
- High Level Voltage Output
- 1500Vrms Transformer Isolation
- ANSI/IEEE C37.90.1-1989 Transient Protection
- Input Protected to 240VAC Continuous
- 160dB CMR
- 95dB NMR at 60Hz, 90dB at 50Hz
- $\pm 0.03\%$ Accuracy
- $\pm 0.005\%$ Linearity
- $\pm 1\mu V/^\circ C$ Drift
- CSA Certified, FM Approved, CE Compliant
- Mix and Match SCM5B Types on Backpanel

A special input circuit on the SCM5B37 modules provides protection against accidental connection of power-line voltages up to 240VAC.

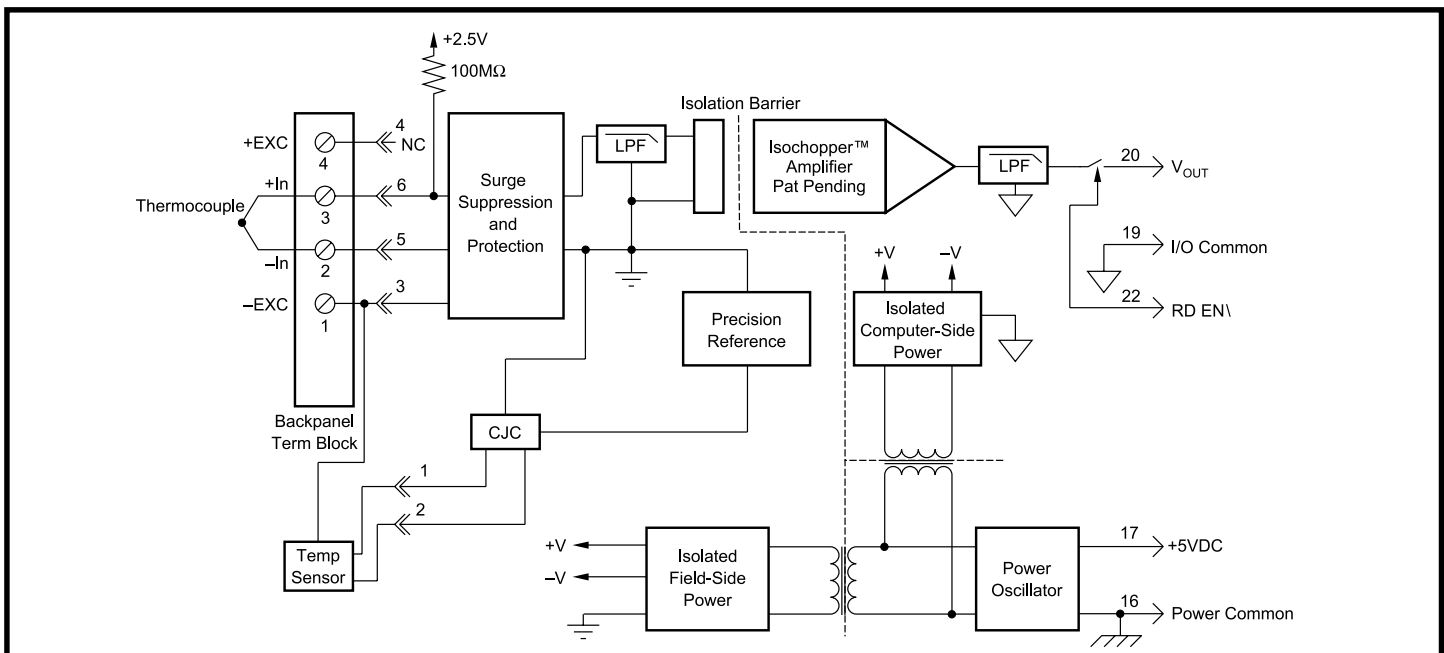

Figure 1: SCM5B37 Block Diagram

Specifications Typical at $T_A = +25^\circ\text{C}$ and +5V power

Module	SCM5B37
Input Range	-0.1V to +0.5V
Input Bias Current	-25nA
Input Resistance	
Normal	50M Ω
Power Off	40k Ω
Overload	40k Ω
Input Protection	
Continuous	240Vrms max
Transient	ANSI/IEEE C37.90.1-1989
CMV, Input to Output	
Continuous	1500Vrms max
Transient	ANSI/IEEE C37.90.1-1989
CMR (50Hz or 60Hz)	160dB
NMR	95dB at 60Hz, 90dB at 50Hz
Accuracy	See Ordering Information
Nonlinearity	$\pm 0.005\%$ Span
Stability	
Input Offset	$\pm 1\mu\text{V}/^\circ\text{C}^{(2)}$
Output Offset	$\pm 20\mu\text{V}/^\circ\text{C}$
Gain	$\pm 25\text{ppm}/^\circ\text{C}$
Noise	
Input, 0.1 to 10Hz	0.2 μVrms
Output, 100kHz	200 μVrms
Bandwidth, -3dB	4Hz
Response Time, 90% Span	0.2s
Output Range	0V to +5V
Output Resistance	50 Ω
Output Protection	Continuous Short to Ground
Output Selection Time (to $\pm 1\text{mV}$ of V_{OUT})	6 μs at $C_{\text{load}} = 0$ to 2000pF
Output Current Limit	+8mA
Output Enable Control	
Max Logic "0"	+0.8V
Min Logic "1"	+2.4V
Max Logic "1"	+36V
Input Current, "0", "1"	0.5 μA
Open Input Response	Upscale
Open Input Detection Time	10s
Cold Junction Compensation	
Accuracy, 25 $^\circ\text{C}$	$\pm 0.25^\circ\text{C}$
Accuracy, +5 $^\circ\text{C}$ to +45 $^\circ\text{C}$	$\pm 0.5^\circ\text{C}$
Accuracy, -40 $^\circ\text{C}$ to +85 $^\circ\text{C}$	$\pm 1.25^\circ\text{C}$
Power Supply Voltage	+5VDC $\pm 5\%$
Power Supply Current	30mA
Power Supply Sensitivity	$\pm 2\mu\text{V}/\%$ RTI ⁽³⁾
Mechanical Dimensions (h)(w)(d)	2.28" x 2.26" x 0.60" (58mm x 57mm x 15mm)
Environmental	
Operating Temp. Range	-40 $^\circ\text{C}$ to +85 $^\circ\text{C}$
Storage Temp. Range	-40 $^\circ\text{C}$ to +85 $^\circ\text{C}$
Relative Humidity	0 to 95% Noncondensing
Emissions	EN50081-1, ISM Group 1, Class A (Radiated, Conducted)
Immunity	EN50082-1, ISM Group 1, Class A (ESD, RF, EFT)

NOTES:

(1) Includes nonlinearity, hysteresis and repeatability. Does not include CJC accuracy.

 (2) This is equivalent to $^\circ\text{C}$ as follows: Type J 0.020 $^\circ\text{C}/^\circ\text{C}$, Types K, T 0.025 $^\circ\text{C}/^\circ\text{C}$, Type E 0.016 $^\circ\text{C}/^\circ\text{C}$, Types R, S 0.168 $^\circ\text{C}/^\circ\text{C}$, Type N 0.037 $^\circ\text{C}/^\circ\text{C}$, Type C, 0.072 $^\circ\text{C}/^\circ\text{C}$.

(3) RTI = Referenced to input.

Ordering Information

Model	TC Type [‡]	Input Range	Output Range	Accuracy ⁽¹⁾	
SCM5B37J	J	-100 $^\circ\text{C}$ to +760 $^\circ\text{C}$ (-148 $^\circ\text{F}$ to +1400 $^\circ\text{F}$)	0V to +5V	$\pm 0.03\%$	$\pm 0.26^\circ\text{C}$
SCM5B37K	K	-100 $^\circ\text{C}$ to +1350 $^\circ\text{C}$ (-148 $^\circ\text{F}$ to +2462 $^\circ\text{F}$)	0V to +5V	$\pm 0.03\%$	$\pm 0.44^\circ\text{C}$
SCM5B37T	T	-100 $^\circ\text{C}$ to +400 $^\circ\text{C}$ (-148 $^\circ\text{F}$ to +752 $^\circ\text{F}$)	0V to +5V	$\pm 0.03\%$	$\pm 0.15^\circ\text{C}$
SCM5B37E	E	0 $^\circ\text{C}$ to +900 $^\circ\text{C}$ (+32 $^\circ\text{F}$ to +1652 $^\circ\text{F}$)	0V to +5V	$\pm 0.03\%$	$\pm 0.27^\circ\text{C}$
SCM5B37R	R	0 $^\circ\text{C}$ to +1750 $^\circ\text{C}$ (+32 $^\circ\text{F}$ to +3182 $^\circ\text{F}$)	0V to +5V	$\pm 0.03\%$	$\pm 0.53^\circ\text{C}$
SCM5B37S	S	0 $^\circ\text{C}$ to +1750 $^\circ\text{C}$ (+32 $^\circ\text{F}$ to +3182 $^\circ\text{F}$)	0V to +5V	$\pm 0.03\%$	$\pm 0.53^\circ\text{C}$
SCM5B37B	B	0 $^\circ\text{C}$ to +1800 $^\circ\text{C}$ (+32 $^\circ\text{F}$ to +3272 $^\circ\text{F}$)	0V to +5V	$\pm 0.03\%$	$\pm 0.54^\circ\text{C}$
SCM5B37C	C	+350 $^\circ\text{C}$ to +1300 $^\circ\text{C}$ (+662 $^\circ\text{F}$ to +2372 $^\circ\text{F}$)	0V to +5V	$\pm 0.03\%$	$\pm 0.29^\circ\text{C}$
SCM5B37N	N	-100 $^\circ\text{C}$ to +1300 $^\circ\text{C}$ (-148 $^\circ\text{F}$ to +2372 $^\circ\text{F}$)	0V to +5V	$\pm 0.03\%$	$\pm 0.42^\circ\text{C}$

‡ Thermocouple Alloy Combinations

Standards: DIN IEC 584, ANS I MC96-1-82, JIS C 1602-1981

Type	Material
J	Iron vs. Copper-Nickel
K	Nickel-Chromium vs. Nickel-Aluminum
T	Copper vs. Copper-Nickel
E	Nickel-Chromium vs. Copper-Nickel
R	Platinum-13% Rhodium vs. Platinum
S	Platinum-10% Rhodium vs. Platinum
B	Platinum-30% Rhodium vs. Platinum-6% Rhodium
C	Tungsten-5% Rhenium vs. Tungsten-26% Rhenium
N	Nickel-14.2% Chromium-1.4% Silicon vs. Nickel-4.4% Silicon- 0.1% Magnesium